



# RUTHMAN COMPANIES

DIN SERIES PUMPS



A CENTURY



RUTHMAN  
COMPANIES

100

100 YEARS OF INNOVATION  
1912 • 2012

OF SERVICE

# The RPE-DIN Series from Ruthmann Pumpen

Quality, Performance,  
Economy, Safety,  
Reliability, Availability.

## The Innovative Solution for every Field of Application:

- Cooling Lubricants for Machine Tools
- Industrial Process and Cooling Water Circuits
- Industrial Heat Recovery Systems
- Spray Booths and Surface Painting Systems
- Industrial Washing and Cleaning Systems
- Filtration and Water Treatment Systems
- Breweries
- Bottle Rinsing and Crate Washing Systems
- Heat transfer Systems
- District Heating
- Sprinkler Systems
- Municipal Water Supply and Transport
- Irrigation
- Heating and Air Conditioning
- and Many More...



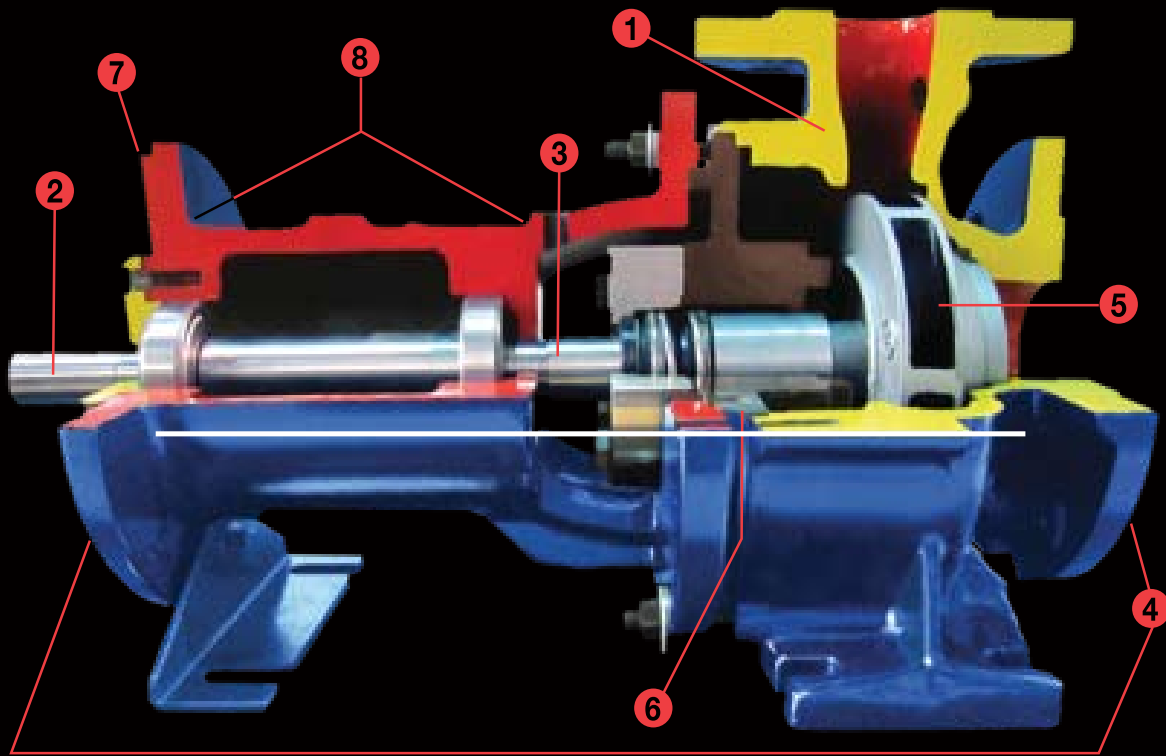

## RPE-DIN Features:

As Shown Above....

1. **Heavy Duty Casings** - increases life under corrosive and erosive conditions. All sizes are self venting with CL discharge. Drain plug is offered as an option.
2. **Heavy Duty Shaft** - Minimum deflection increases life for less maintenance.
3. **Renewable Shaft Sleeve**- sleeve is easily removed, and is relieved to allow for temperature changes.
4. **Rabeted Fits** - Accurately machined rabbets ensure positive alignment, longer seal life, and easy replacement of spare rotating parts when maintenance is needed.
5. **Enclosed Trimmed Impeller** - trimmed to specified duty point using less system power.
6. **Stem Plate** - Designed to be interchangeable with Burgmann single type seals, Burgmann double type cartex seals or packing.
7. **Bearing Housing**- Standard for use of an IEC type motor arrangement. May also be machined for use with NEMA C-Face motors.
8. **Bearing Housing**- RPE Bearing housings are also more concentric, with all bearing bores machined from a single end. This feature eliminates possible concentricity problems

## Additional Features:

- Standard ball bearing housing sizes that interchange with many pump models.
- Inlet and outlet flanges are of raised face design, allowing for more positive sealing of flanges.
- Internal pump hardware material is 316 stainless steel as standard.
- Shaft sleeve material is 316 stainless steel as standard.
- Side port volute drain featured for ease of pumpage removal during repair.
- Pump dimensions are designed to match the DIN 733 standard.
- Volute inlet and outlet flanges are to PN16 as a standard. Can be produced per customer specifications if required.
- With just a change of the shaft sleeve and seal gland, the size of the mechanical seal can be changed.
- Ball bearing housing castings are designed for use with oil, grease or greased for life ball bearings. This reduces the pump parts inventory and allows for quicker delivery to the customer.
- Carbon wear ring material is standard.

# Cost Savings through Energy Optimization

High Efficiency Rated Motors and the Right Pump Selection Make it Happen.



## Standard Top Rated Motors

The Low Voltage Motors used in the Ruthman DIN Pump Systems exceed the requirements of the most up to date Energy Efficiency Standards.

This assures the most energy savings possible out of your system when incorporating the Ruthman DIN Series Pumps.

Ruthman DIN Systems are available with standard top rated IEC motors, and may be machined for C-Faced NEMA motors.

## Maximizing your energy potential by Minimizing your operation costs...

RPE products are designed to manage the costs and energy consumption of your entire operation. RPE will help choose the proper product for each application, offering practical solutions down to the efficiency of the smallest component of your Ruthman Pump. Our goal is to place the product which best assures your total system's optimization, increasing your maximum efficiency.

### Average Energy Cost Investments for Industrial Pumps

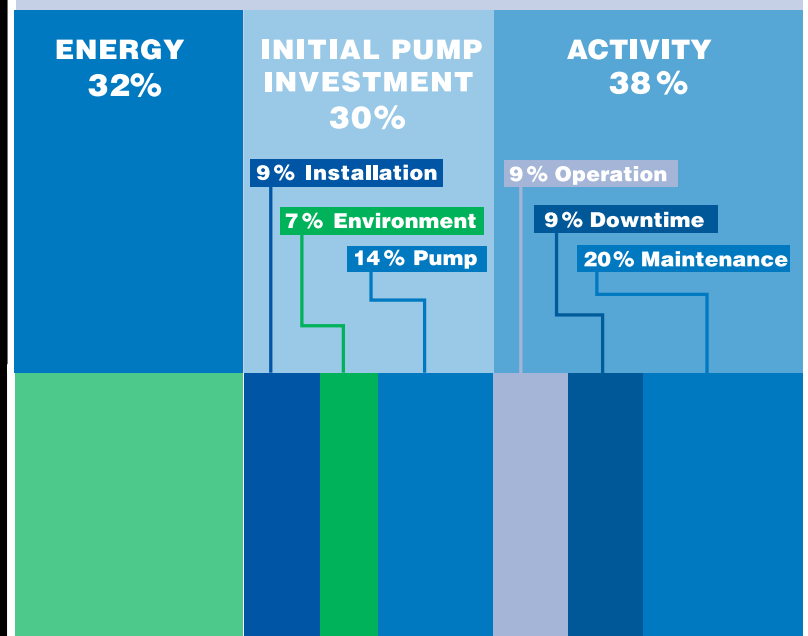

## Making the Right Pump Choice

With the expertise of the Ruthman Company support team, your pumping needs will be tailored to your particular system's requirements, either selecting our standard line, or custom built systems for unique situations.

Ruthman representatives will provide a complete system analysis, helping choose the equipment for optimum performance and energy savings throughout your entire process.

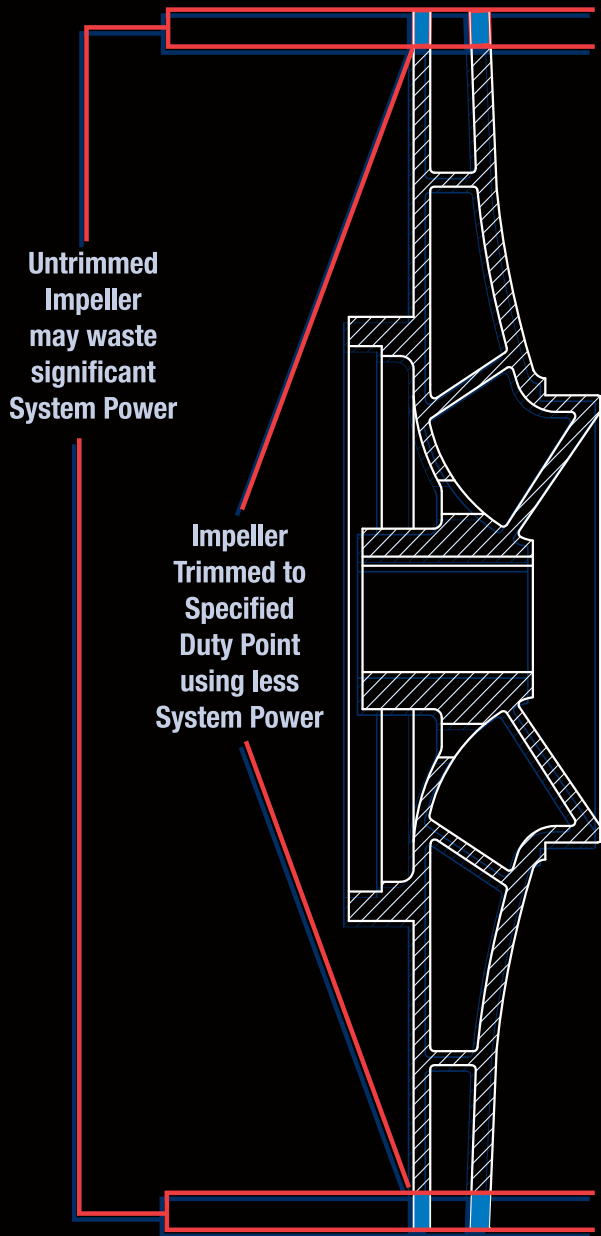

## Maximum Efficiency Built In...

...With the advantages of the Ruthman Precision Trimmed Impellers and easily replaceable Wear Rings.

## Replaceable Carbon Wear Rings

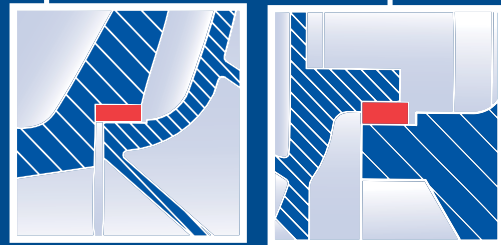

Pump efficiency is determined by the distance between the impeller and the casing. Replaceable wear rings make maintenance simple.

## Trimmed Impellers

Precision Trimmed Impellers insure the highest possible energy efficiency. This feature reduces the impeller's outside diameter to match exactly the required duty point based on the exact customer specifications.

# Interchangeability Conversions Made Simple

Ruthman Company DIN Pumps feature engineered parts interchangeability which insures you are easily and quickly able to convert to the pump assembly that matches your application.

## Conversion from Single type Seal to Cartridge type seal....

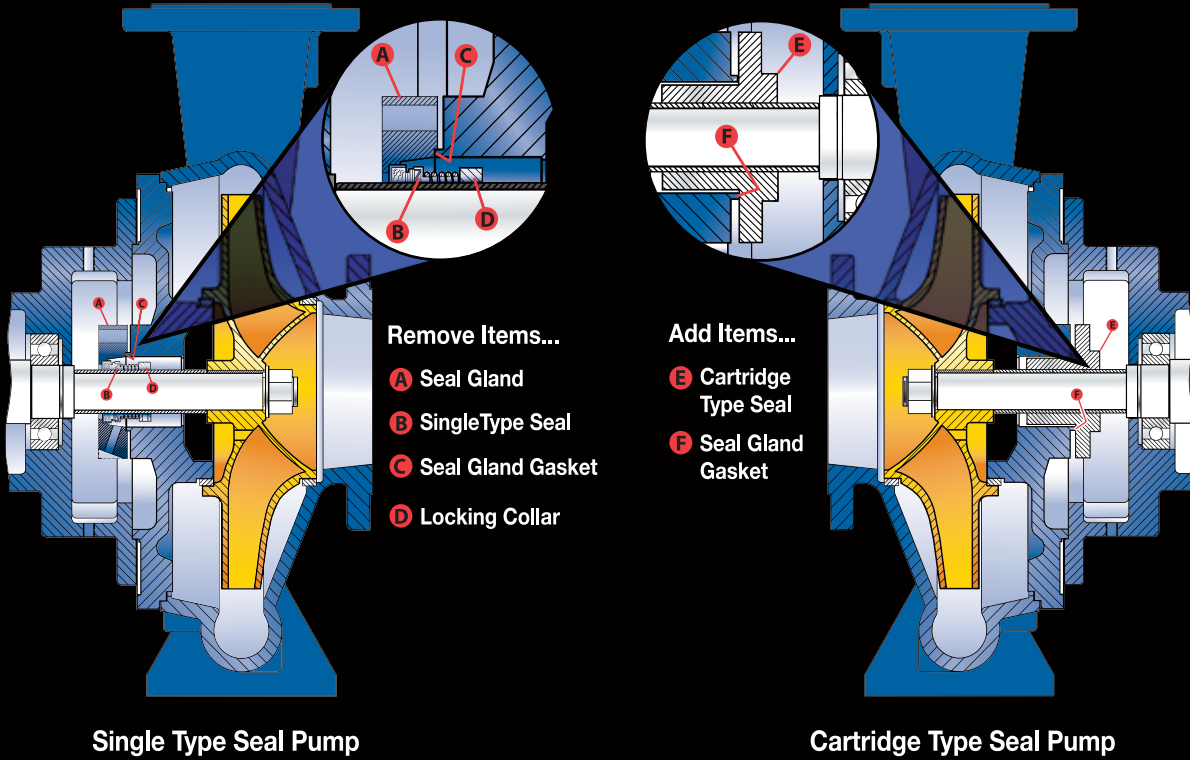

## Conversion from Single Type Seal to Packing Type Seal

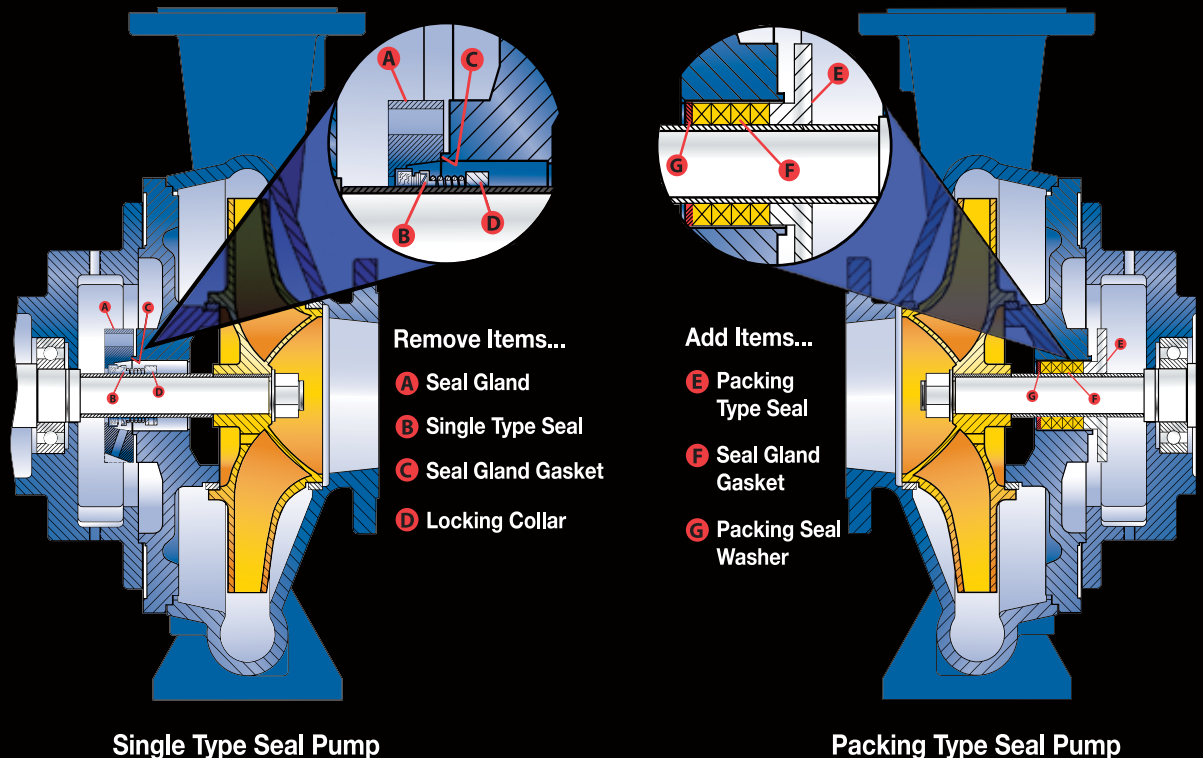

A



Cartridge Type Seal



Single Spring Type Seal



Packing Type Seal

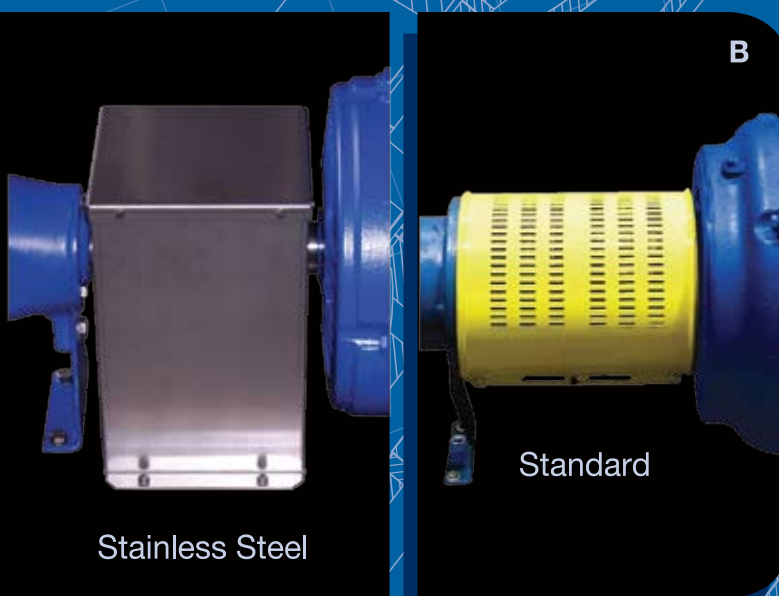

B

Stainless Steel

Standard



C

## RPE-DIN Options

### A. Standard Bore Stuffing Box

Accommodates most seal sizes and types such as cartridges, single spring and packing.

### B. Coupling Guards

Guards, stainless steel or standard for use around rotating parts for safety requirements.

### C. Base Plates

Construction in fabricated steel.

Base plates are also supplied with jack bolts to aid in alignment.

# DIN Performance Charts at 50hz

## 2850 r/min



## 1450 r/min

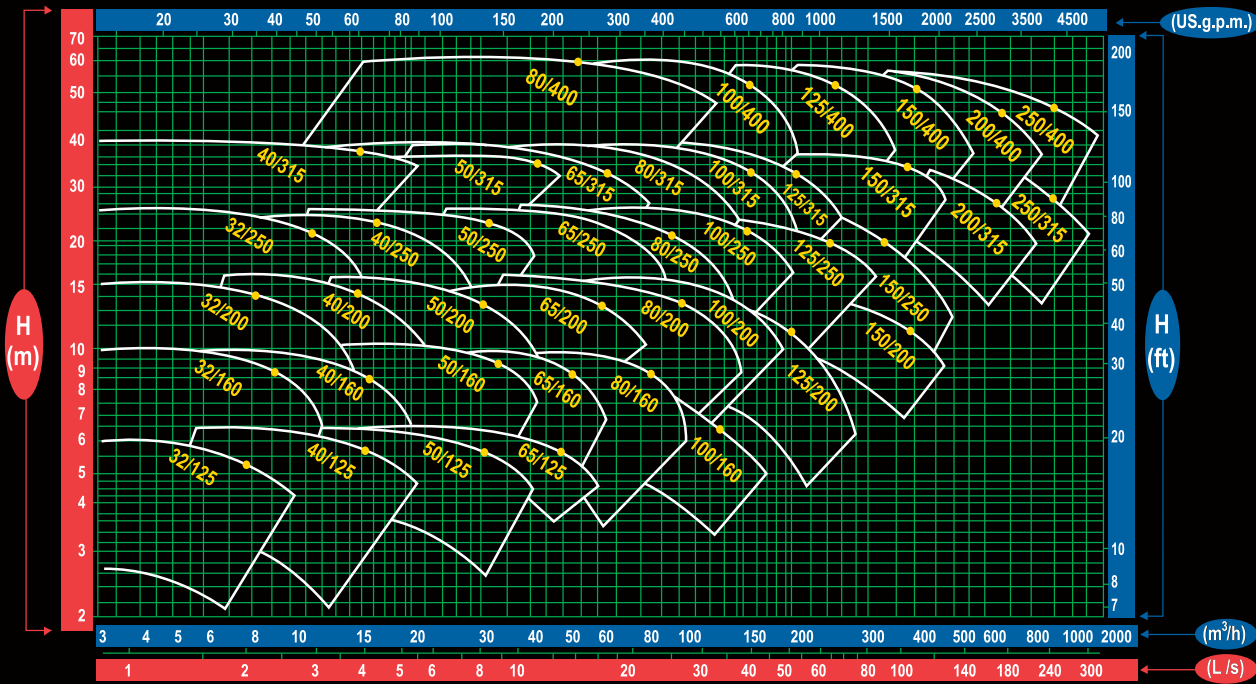



# DIN Performance Charts at 60hz

3500 r/min

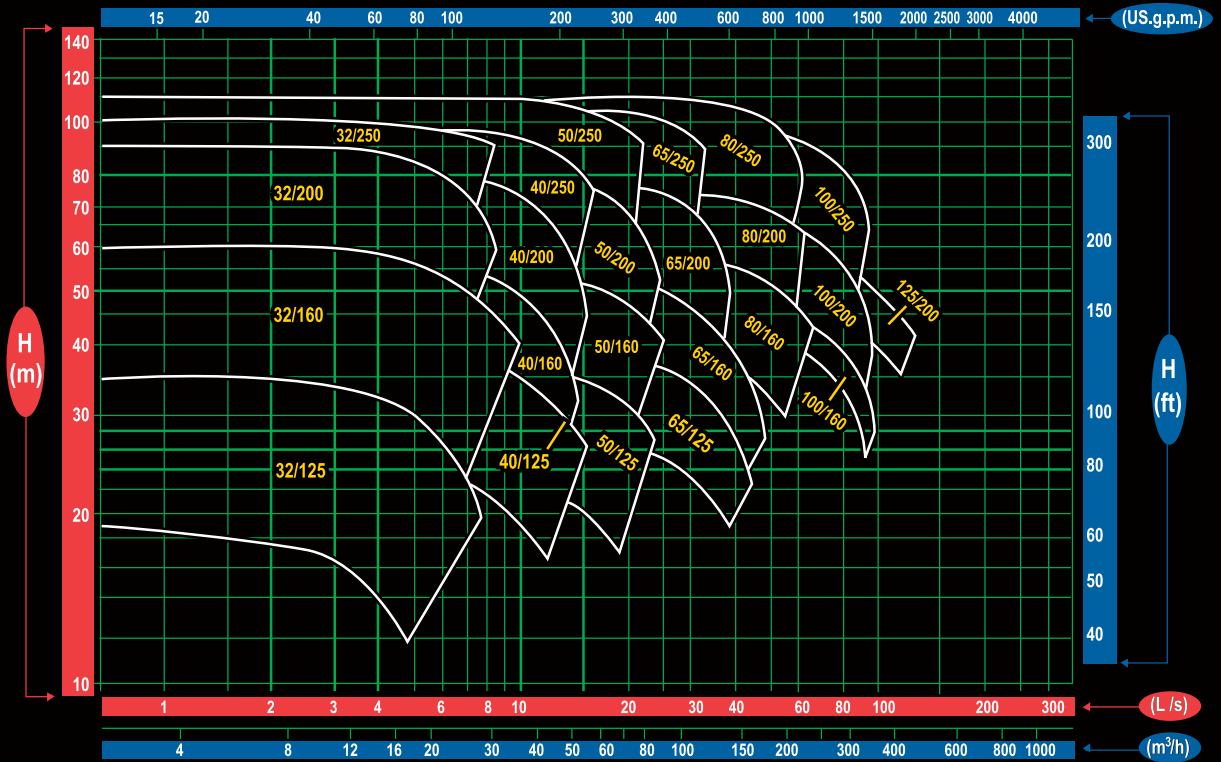

1750 r/min

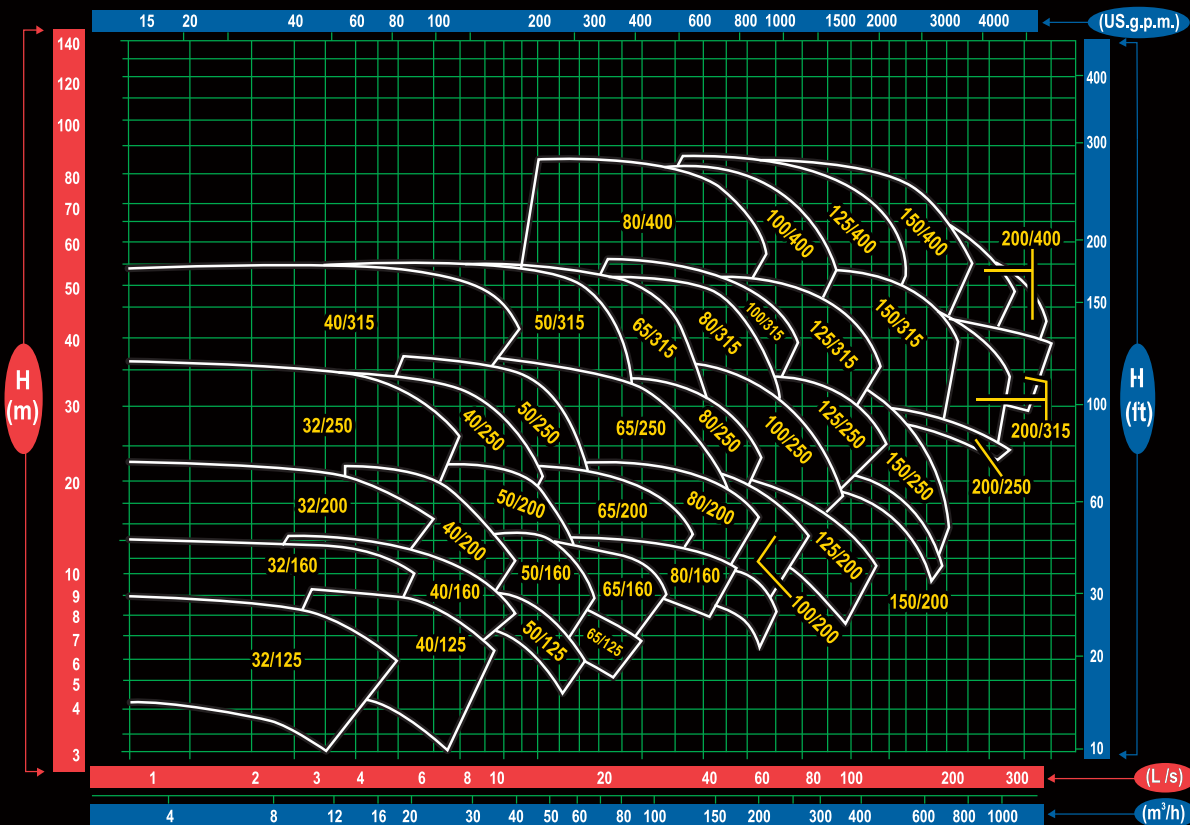

## All Inclusive Service and Maintenance...

...is guaranteed with your DIN Pump investment with Ruthman Companies. From the initial on-site installation process through maintenance, repair and rehabilitation issues, the RPE technical staff is guaranteed to be accessible on an around the clock schedule. The Ruthman Companies repair team at our facility has the ability and 100 years of industry expertise to service virtually all makes and models of industrial pumps and accessories.



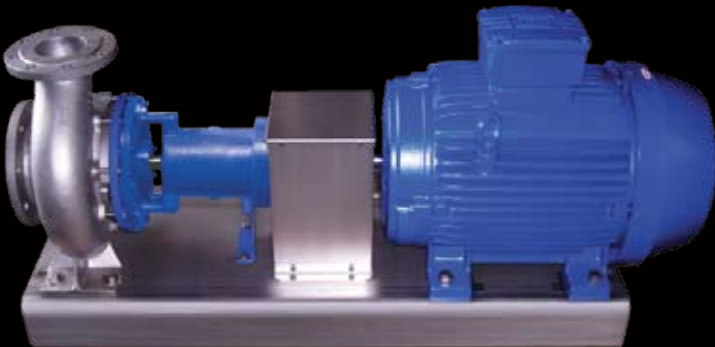

## Why DIN Standards?

For a Century now, the Ruthman Companies has understood that being the best demands being ahead of the curve on industry quality standards. As a leading worldwide manufacturer of centrifugal pumps, Ruthman Companies embrace the DIN Standards because they promote rationalization, quality, safety, and environmental protection, as well as improving communication between industry, technology, science, government and the public domain. Most important, adherence to these standards, as well as our own is further assurance to our Ruthman Companies partners and customers of the commitment to excellence and service established and maintained for 100 years...  
....and counting.





RUTHMANCOMPANIES.COM

Your Global Source for Ruthman Company DIN Series Pumps

In the British Isles,  
Western Europe, Africa and  
the Middle East

**BIRMINGHAM PUMP  
SUPPLIES LIMITED**

Phone: +44 (0) 121 503 3000  
www.birminghampumps.co.uk



In Europe

**RUTHMANN PUMPEN**

Phone: +49 (0) 2403 5595 0  
Web: www.ruthmannpumpen.de

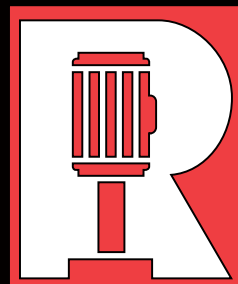

In China  
**GUSHER PUMPS  
SHANGHAI**

Phone: 86-021-26616611  
Web: www.gusher.com



In North  
and South America  
**GUSHER PUMPS**

Phone: 859-824-3100  
Web: www.gusher.com



A RUTHMAN COMPANY



A CENTURY

OF SERVICE